

PROPER USE GUIDELINES

Cumulative Trauma Disorders can result from the prolonged use of manually powered hand tools. Hand tools are intended for occasional use and low volume applications. A wide selection of powered application equipment for extended-use, production operations is available.

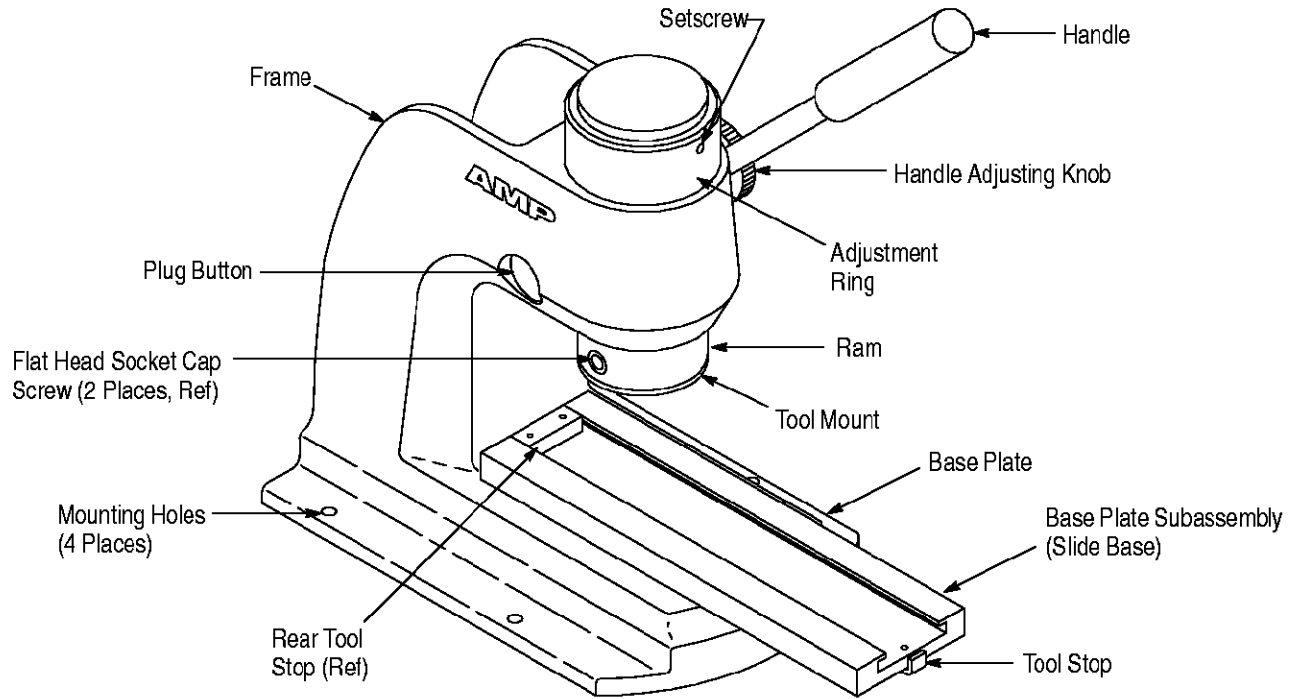

Figure 1

1. INTRODUCTION

Manual Arbor Frame Assembly 91085-2, shown in Figure 1, provides the necessary force to drive various tooling assemblies (upper and lower tooling) to be used for a specific purpose.

NOTE Dimensions in this instruction sheet are in millimeters [with inches in brackets]. Figures are not drawn to scale.

Reasons for reissue of this instruction sheet are provided in Section 7, REVISION SUMMARY.

2. DESCRIPTION

The arbor frame assembly features a bench-mountable frame, handle, handle adjusting knob, adjustment ring, ram, base plate, tool mount, and base plate subassembly (slide base). The handle is adjustable for storage.

3. SETUP AND OPERATION

1. Grasp the handle, and loosen the handle adjustment knob sufficiently for the handle to slide. FULLY extend the handle. Tighten the knob,

making sure that the screw enters the last hole in the handle.

2. Secure the arbor frame assembly to a workbench to ensure stability during operation. Refer to Figure 2 for mounting hole dimensions.

Mounting Hole Dimensions

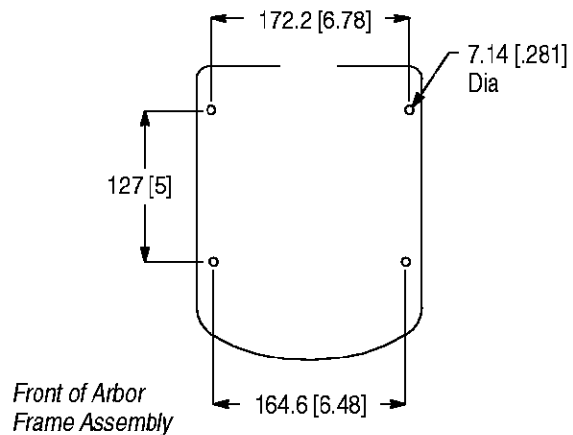

Figure 2

3. Secure the appropriate upper tooling to the tool mount according to the instructions packaged with the upper tooling.
4. Remove the tool stop from the base plate subassembly (slide base).
5. Secure the appropriate lower tooling to the base plate according to the instructions packaged with the lower tooling.
6. Re-install the tool stop onto the base plate subassembly.
7. To actuate the ram, pull down on the handle until the upper tooling bottoms on the lower tooling. To retract the ram, raise the handle.

NOTE

Before beginning production, make sure that the ram height is properly set according to Paragraph 4.1 and, if desired, adjust the handle according to Paragraph 4.2.

4. RAM HEIGHT ADJUSTMENT

IMPORTANT: The ram height should be set before adjusting the handle.

4.1. Ram Height Adjustment

After installing the tooling assembly, it might be necessary to adjust the height of the ram. Adjust the ram height as follows:

1. Determine the closed ram height dimension required for the application.
2. Measure the distance between the bottom surface of the upper tooling and the upper surface of the lower tooling. Determine the direction (UP or DOWN) that the ram must be moved.
3. Loosen the setscrew on the adjustment ring, turn the adjustment ring *clockwise* to increase ram height, or *counterclockwise* to decrease ram height, then tighten the setscrew. Continue making adjustments until the proper closed ram height dimension is attained.

4.2. Adjusting the Handle

DANGER

To avoid personal injury when adjusting the handle, STAY CLEAR OF THE HANDLE. Depending on position, the weight of the ram could force the handle to rotate quickly.

1. Using the tip of a small flat-blade screwdriver, remove the plug button. Remove the socket head cap screw and washer from the bore of the frame.
2. Grasp the adjustment ring, and pull the pinion (small diameter gear in bore of frame) out of the frame just enough to disengage it from the gear teeth in the ram. Allow the ram to drop *slowly* until the adjustment ring rests on the frame.

CAUTION

If the adjustment ring is NOT held in place when the pinion is removed, the ram will drop and the adjustment ring will slam onto the frame.

3. Rotate the handle to the desired position. Ensure that the pinion rotates with the handle.
4. Push the pinion into the bore of the frame until it engages the gear teeth in the ram.
5. Re-install the socket head cap screw and washer. Re-install the plug button.

5. MAINTENANCE AND INSPECTION

5.1. Inspection

It is recommended that the arbor frame assembly be inspected according to Figure 3 immediately upon arrival at your facility (and at regularly scheduled intervals thereafter) to ensure that it has not been damaged during handling.

5.2. Lubrication

To prolong the useful life of the arbor frame assembly, and to provide the smoothest operation, lubricate monthly as follows:

NOTE

Though recommendations call for lubrication at least once a month, the frequency should be based on amount of use, working conditions, and established company policies.

1. Remove the two screws that secure the tool mount to the ram. Remove the tool mount.
2. Remove the lower tooling.
3. Move the ram to the bottom of its stroke (the adjustment ring should bottom on the base plate). *Note the position of the handle.* Loosen the handle adjustment knob sufficiently for the handle to slide from its mounting hole. Remove the handle.
4. Using a small flat-blade screwdriver, turn the spring plunger (refer to Figure 3 for location) *counterclockwise* until it no longer contacts the ram.
5. Grip the adjustment ring, and pull it upward, then remove the ram.
6. Apply ANDEROL 757® lubricant, or equivalent, to the gear teeth on the ram and to the bore of the frame.
7. Re-assemble the ram into the bore with the grooved side of ram aligned with the spring plunger. Ensure that the gear teeth in the ram engage the teeth of the pinion (small diameter gear in bore of frame) so that the handle position will be the same as noted in Step 2 when the adjustment ring bottoms.
8. Turn the spring plunger *clockwise* until it bottoms lightly on the ram, then back off one-half of a turn.
9. Re-assemble the handle and upper tooling and lower tooling. Ensure proper alignment of tooling before operating the arbor frame assembly.

10. Remove any excess lubricant from the outer surface of the frame and adjustment ring with a soft cloth.

For customer repair service, please contact a representative at 1-800-526-5136.

6. REPLACEMENT AND REPAIR

Customer-replaceable parts are listed in Figure 3. A complete inventory should be stocked and controlled to prevent lost time when replacement of parts is necessary. Parts other than those listed should be replaced by Tyco Electronics to ensure quality and reliability. Order replacement parts through your representative, or call 1-800-526-5142, or send a facsimile of your purchase order to 717-986-7605, or write to:

CUSTOMER SERVICE (038-035)
TYCO ELECTRONICS CORPORATION
PO BOX 3608
HARRISBURG PA 17105-3608

7. REVISION SUMMARY

Revisions to this instruction sheet per EC 0990-0086-01 include:

- Updated document to corporate requirements
- Modified Figure 1
- Added information to Section 3
- Added Paragraph 4.2
- Modified Step 1 in Paragraph 5.2

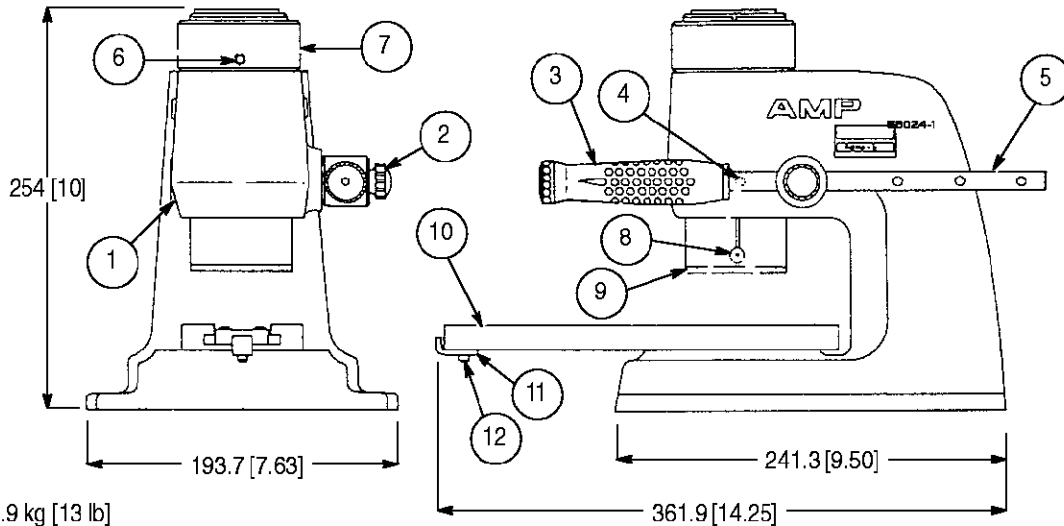

Weight: 5.9 kg [13 lb]

REPLACEMENT PARTS

ITEM	PART NUMBER	DESCRIPTION	QTY PER ASSEMBLY
1	2-22484-1	BUTTON, Plug	1
2	27898-1	KNOB, Handle Adjusting	1
3	19120-1	GRIP, Handle	1
4	28053-2	PLUNGER, Spring	1
5	311481-1	SHAFT, Handle	1
6	22736-6	SETSCREW, Socket	1
7	311534-1	RING, Adjustment	1
8	1-21003-9	SCREW, Flat Head Socket Cap	2
9	126289-1	MOUNT, Tool	1
10	126328-3●	SUBASSEMBLY, Base Plate (Slide Base)	1
11	126930-1	TOOL STOP	1
12	7-21000-4	SCREW, Socket Head Cap	1

● Includes Items 11 (Tool Stop) and 12 (Screw)

Figure 3